

# GRUPO ANTOLIN CARBON NANOFIBRES (GANF) HIGH QUALITY LOW COST INDUSTRIAL PRODUCTION

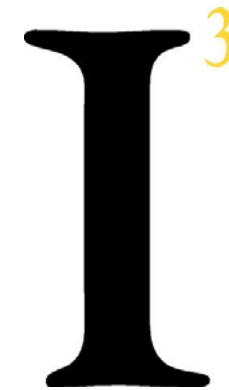
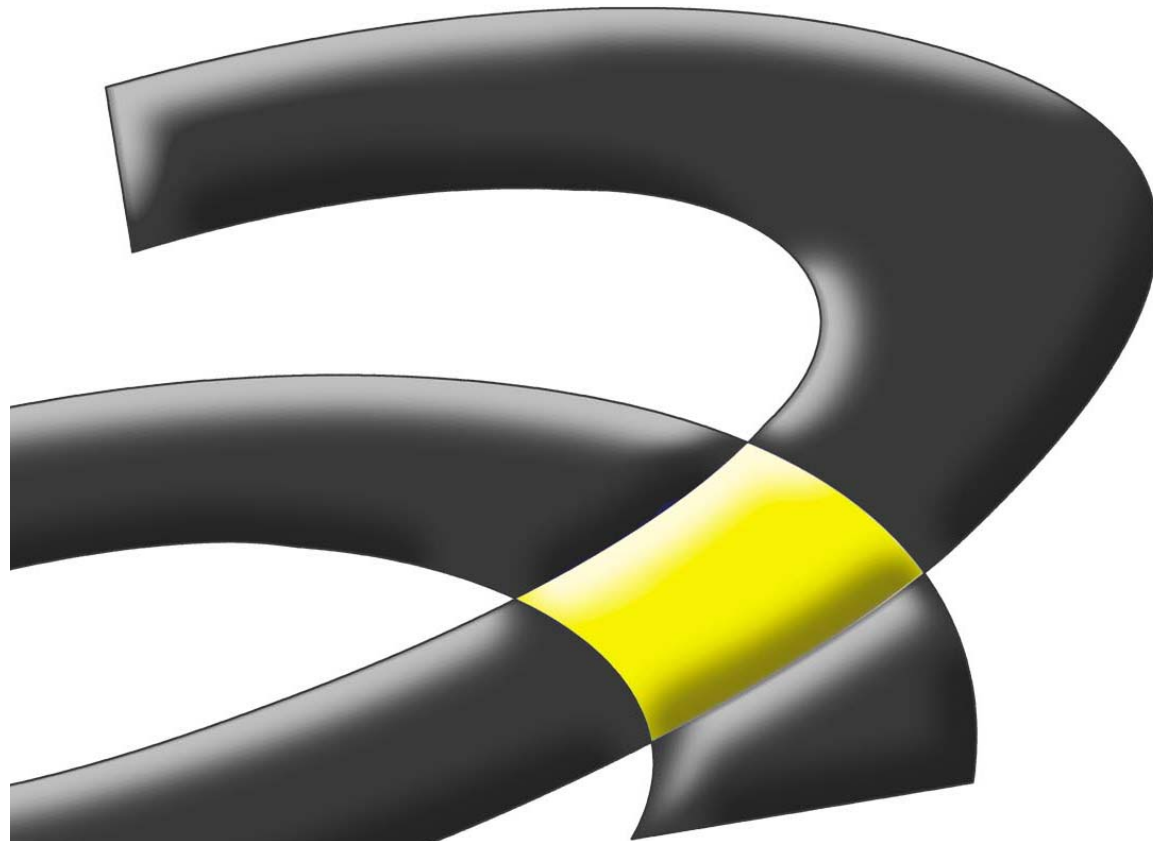
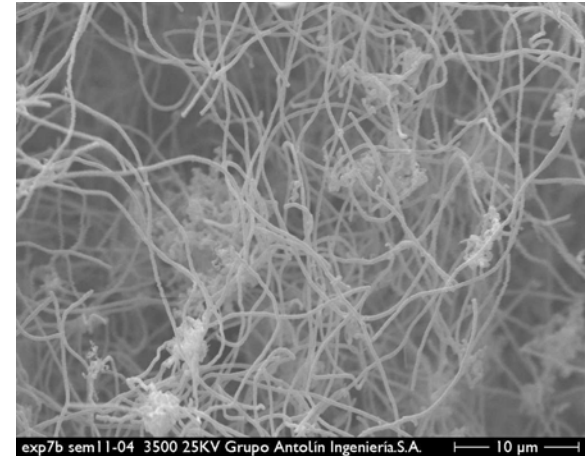

Initiative  
Innovation  
Integration

- **Grupo Antolin is manufacturing Carbon Nanofibers continuously at industrial scale by the floating catalyst technique.**
- **The product manufacturing method developed and implemented is the cheapest one reported because of the low cost raw materials used.**
- **The quality of the currently fabricated Carbon Nanofibers is excellent.**

- Carbon Nanofibres manufacturing technology by CVD - two techniques:
  - Growing on metal catalysts seeded on a substrate.
  - Floating catalyst technique.
  
- Carbon Nanofibres growing on a substrate: Non continuous, need of separation from the substrate.

2

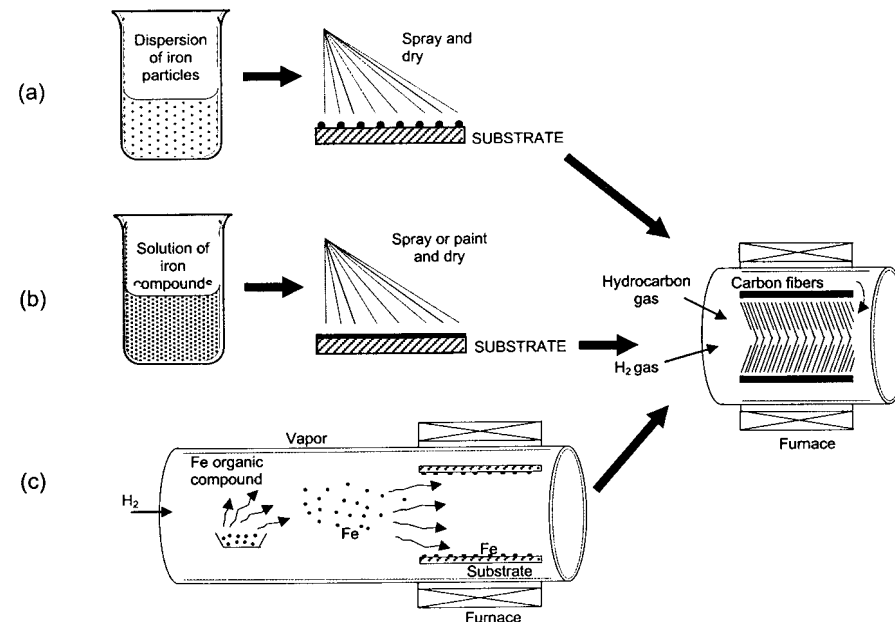

## State of art of the Carbon Nanofibres technology: CVD floating catalyst technique

In the floating catalyst technique, metal catalysts are introduced in a continuous way by the upper end of a reaction chamber. The catalysts descend through the furnace and **the hydrocarbons used are decomposed on the surface of the catalysts growing and thickening the nanofibres.**

Some of the **most characteristic parameters of the process** are:

- Temperature: 1050 - 1100°C.
- Catalytic particles : Elements of group VIII of the periodic chart like iron, nickel or cobalt, or alloys of them.
- Carbon source: Hydrocarbons like benzene, n-hexane, methane and acetylene.

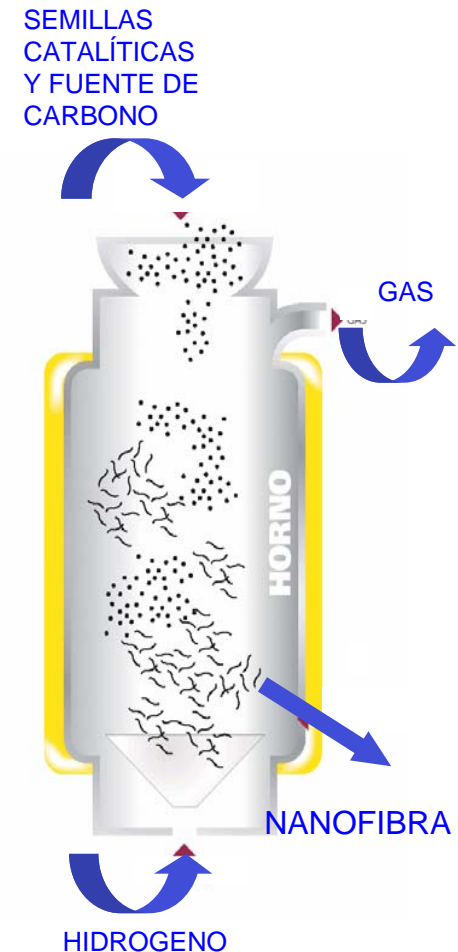

## Patent applications of Grupo Antolin regarding carbon nanofibers manufacturing:

- European Patent application EP04381014: FURNACE FOR THE MANUFACTURE OF CARBON FIBRES, PROCEDURE FOR OBTAINING USING SAID FURNACE AND THE FIBRE THUS OBTAINED**

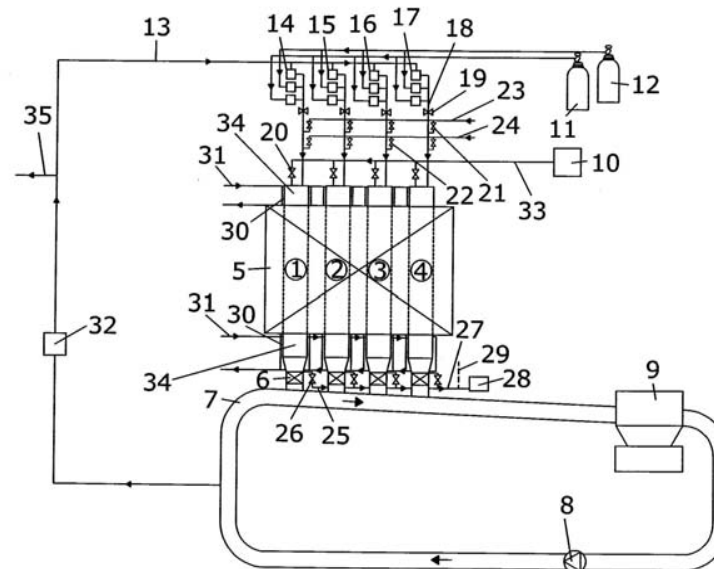

- European Patent application EP04381015: GAS REUSING SYSTEM FOR CARBON FIBRE MANUFACTURING PROCESSES**

## Product description: Carbon Nanofibres

- **Grupo Antolin Carbon Nanofibres (GANF) are *sub-micron Vapor Grown Carbon Fibres (s-VGCF)* with very small diameter (20-80 nm), excellent aspect ratio (>100), and highly graphitic structure (>60%).**
- **Grupo Antolin Carbon Nanofibres are characterised by outstanding mechanical and transport properties (exceptionally high electrical and thermal conductivity).**
- Other properties that set Grupo Antolin carbon nanofibres as an extraordinary product to be used in several industrial applications are:
  - Low coefficient of thermal expansion
  - Recyclable composite parts
  - Anticorrosive properties
  - High specific surface area

## Grupo Antolin Carbon Nanofibres (GANF): Product Technical Data Sheet

MEASURED PROPERTY	UNIT	GANF 1	GANF 3
FIBRE DIAMETER (TEM)	nm	20 - 80	20 - 80
FIBRE LENGTH (SEM)	µm	>30	>30
BULK DENSITY	g/cc	>1,97	>1,97
APPARENT DENSITY (as grown)	g/cc	0,009	0,008
APPARENT DENSITY (stripped and debulked)	g/cc	0,060	0,045
SPECIFIC SURFACE AREA BET (N2)	m <sup>2</sup> /g	150-200	100-200
SURFACE ENERGY (stripped and debulked)	mJ/m <sup>2</sup>	≈120	≈86
GRAPHITIZATION DEGREE	%	≈70	pending
ELECTRICAL RESISTIVITY	Ohm·m	1·10 <sup>-3</sup>	1·10 <sup>-3</sup>
METALLIC PARTICLES CONTENT	%	6-8	6-8
YOUNG MODULUS (theoretic)	GPa	230	230
TENSILE STRENGTH (theoretic)	GPa	2,7	2,7

# Grupo Antolin Carbon Nanofibres (GANF): Morphology and TEM diameter distribution

7

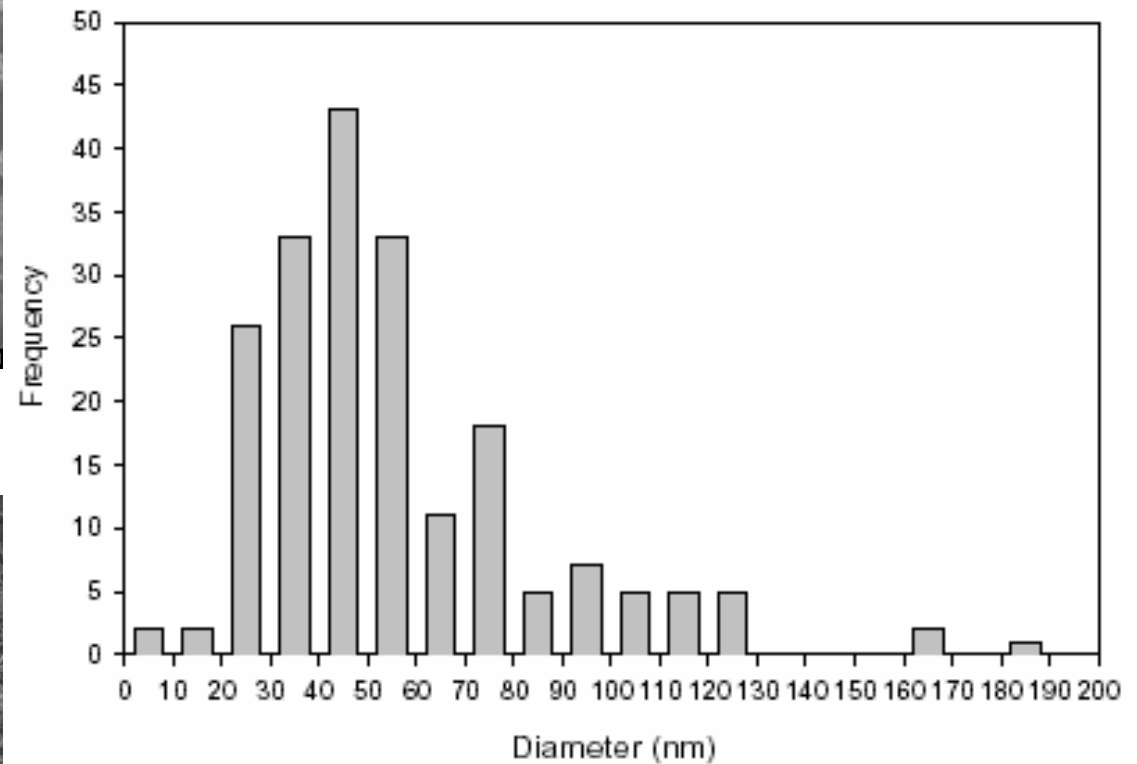
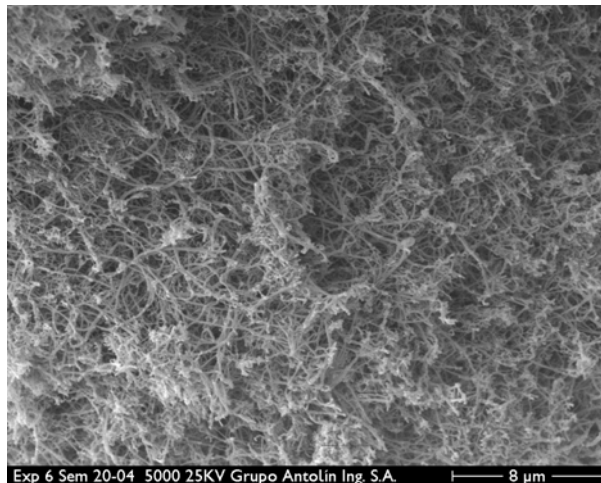
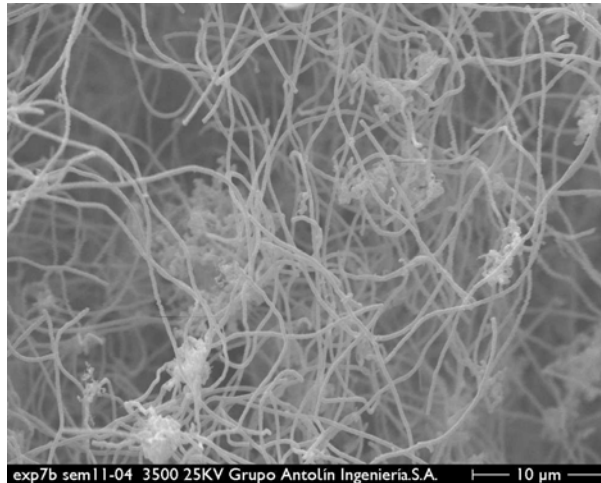

## Grupo Antolin Carbon Nanofibres (GANF)

- **Grupo Antolin Carbon Nanofibers (GANF) are more than 1000 times cheaper than commercial carbon nanotubes and also cheaper than other commercial carbon nanofibers.**

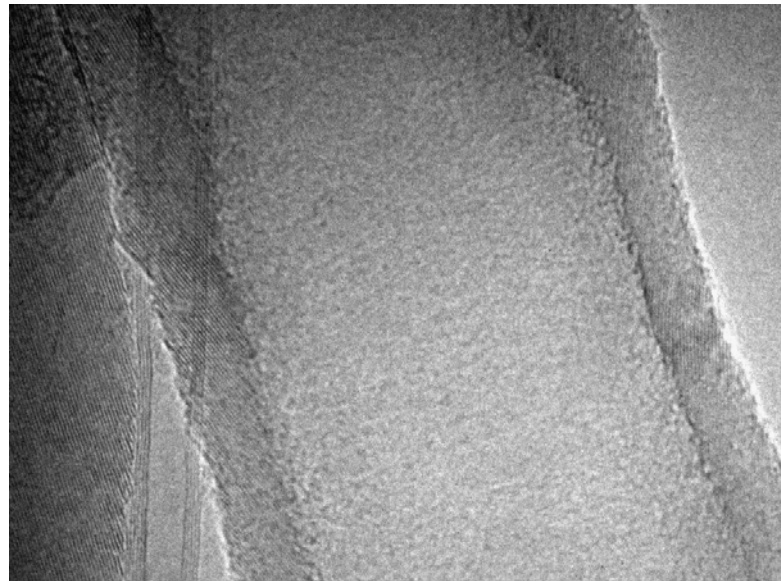

## Main Advantages of Grupo Antolin Carbon Nanofibers

### □ Benefits improvement:

- Grupo Antolin Carbon Nanofibers have engineering properties characteristic of highly graphitic carbon fiber such as **electrical and thermal conductivity and moderate coefficient of thermal expansion**.
- Their small diameter and high aspect ratio, allow to manufacture **dissipative or conductive injection plastic parts** with **lower filler loadings** than in the case of conventional materials.
- **Some of these Benefits are:**
  - Minimal effect on surface quality (parts of class A finishing)
  - Isotropic dispersion for uniform conductivity and mold shrinkage
  - Lower loadings to meet electrical conductivity requirements compared with alternative fillers
    - Minimal change to neat resin's mechanical properties
    - Minimal increase in melt viscosity for easy processing

## Main Advantages of Grupo Antolin Carbon Nanofibers

### □ Recyclability:

- It is a characteristic of reinforced compound materials with carbon nanofibres.
- This characteristic will acquire an special relevance when the European directive “*End of Life Vehicles Directive*” (ELVD) takes effect, because it would be possible to *replace non-recyclable inorganic reinforcements and/or fillers such as glass fibres, currently used at very large-scale in the automotive sector.*
- **Some applications due to recyclability:**
  - *Automotive sector. thermoplastic reinforcement* (glass fibre replacement), *underhood components* subjected to mechanical efforts at high temperatures (thermal stability) .

# CARBON NANOFIBER APPLICATIONS

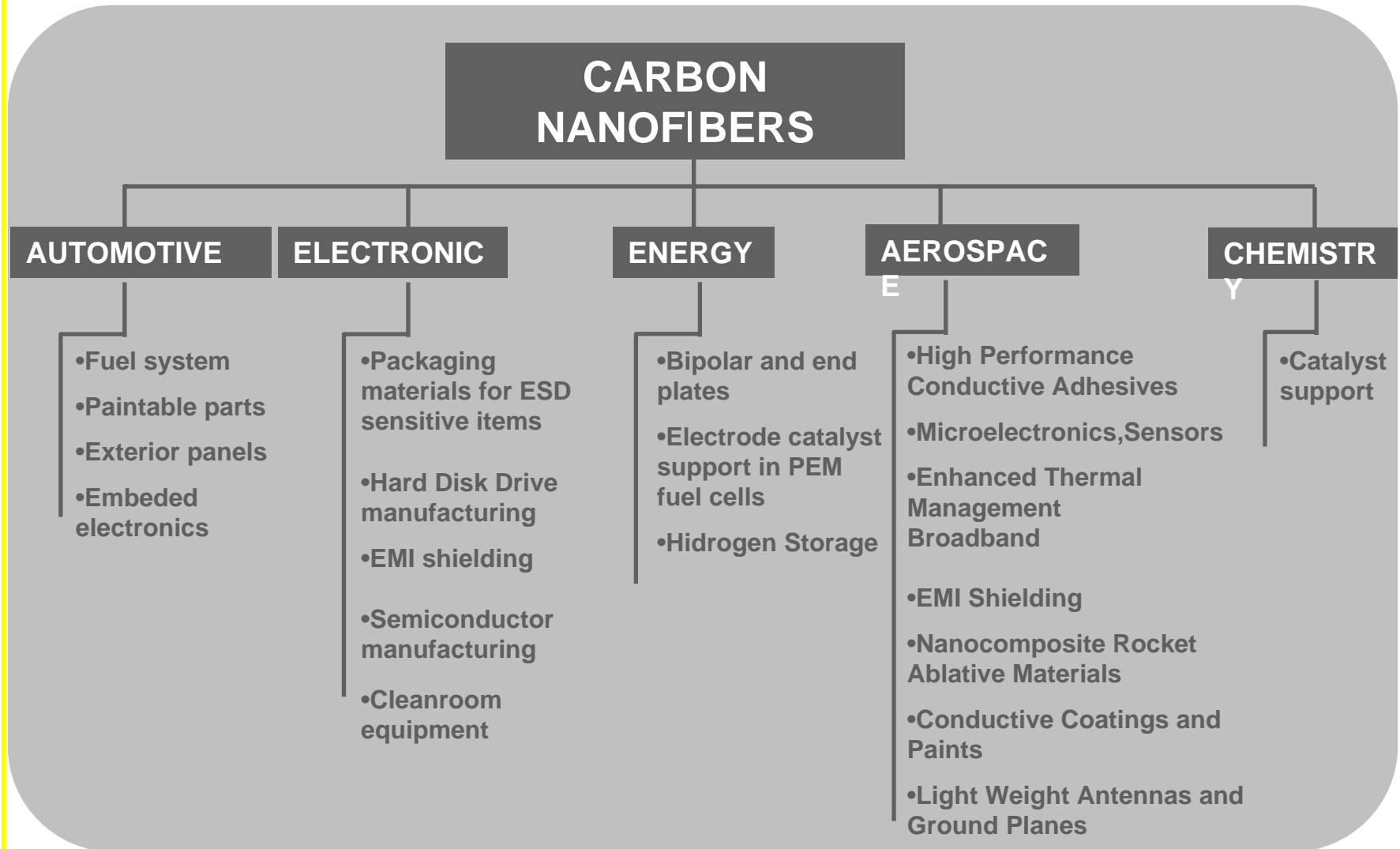

# CARBON NANOFIBER APPLICATIONS

## FUEL SYSTEMS

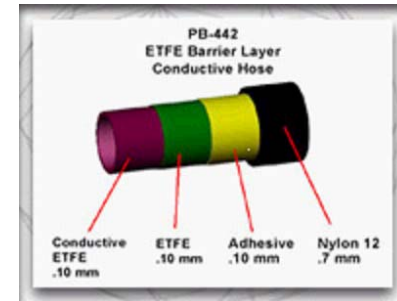
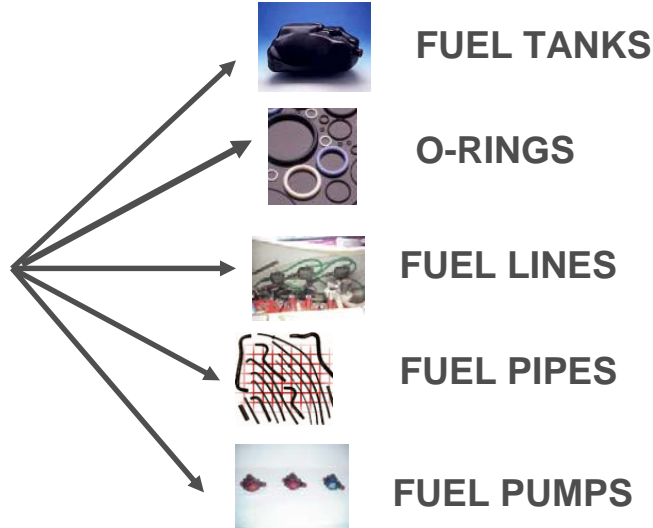

Today, **60 per cent of cars on America roads have fuel lines containing Hyperion's carbon nanotubes.** Their high conductivity dissipates any electric charge that might build up and generate a dangerous spark as the fuel flows past the nylon walls of the fuel line. ([www.impactlab.com](http://www.impactlab.com))

Carbon nanotube-filled plastics are being used in several commercial automotive applications in North America, Europe and Japan.

As N. American OEMs require more and more fuel system components to have ESD levels of conductivity, there is increasing interest in nanotube filled composites for pumps, filters, connectors, and fuel rails

A new fluoropolymer/nanotube compound is being used to make O-rings for automotive fuel connectors.

<http://www.plasticstechnology.com/articles/200411fa2.html>

# CARBON NANOFIBER APPLICATIONS

PLASTIC COMPONENTS  
ELECTROSTATICALLY  
PAINTABLE



13

Savings in the process, manufacturing parts with a conductive nanocomposite, instead of applying a primer coat:

1. The cost of the primer is eliminate 1-2% of the cost
2. The labor needed to apply the primer is taken out
3. The VOCs from the primers are also eliminated. (about 0.03 lb./par)

Carbon nanotubes are finding success in Europe, where the industry is trending toward thermoplastic fenders for reduced weight, recycling requirements and increase styling freedom.

Over the last three years, a major automotive OEM in Europe has been using carbon nanotubes in GE's Noryl GTX nylon/PPO alloy to mold exterior fenders. This conductive nanocomposite allows for electrostatic painting.

<http://www.plasticstechnology.com/articles/200411fa2.html>

TRANSPORT AND STORAGE CONTAINERS FOR SILICON WAFERS DURING THE MANUFACTURE OF COMPUTER CHIPS

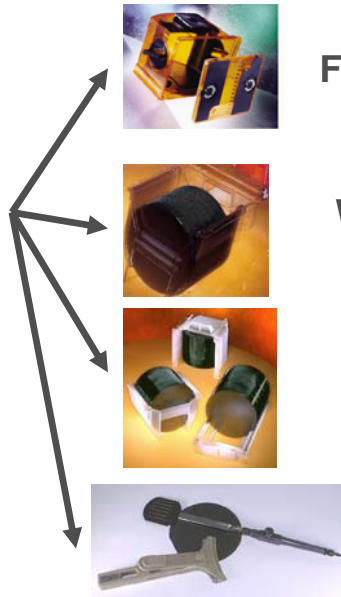

FRONT OPENING UNIFIED PODS (FOUF's)

WAFER SHIPPING BOX AND TRAYS

WAFER CARRIER

MANUAL WAND FOR SEMICONDUCTO WAFER HANDLING

Conductive plastic resins filled with graphite Fibril nanofibers can be used in molded cleanroom tools such as **wafer trays**, bar code scanners, and tweezers. The resins produce a nonsloughing, glossy surface with low outgassing levels. The nanofibers measure 0.01  $\mu\text{m}$  diam. Uniform distribution of the fibers ensures a dissipative range of  $10^4$  to  $10^6$  , eliminating ESD hotspots. Grades include PC, PBT, PPS, PP, and thermoformable PET-G conductive sheet.  
<http://www.micromagazine.com/archive/99/11/top40.html>

# CARBON NANOFIBER APPLICATIONS

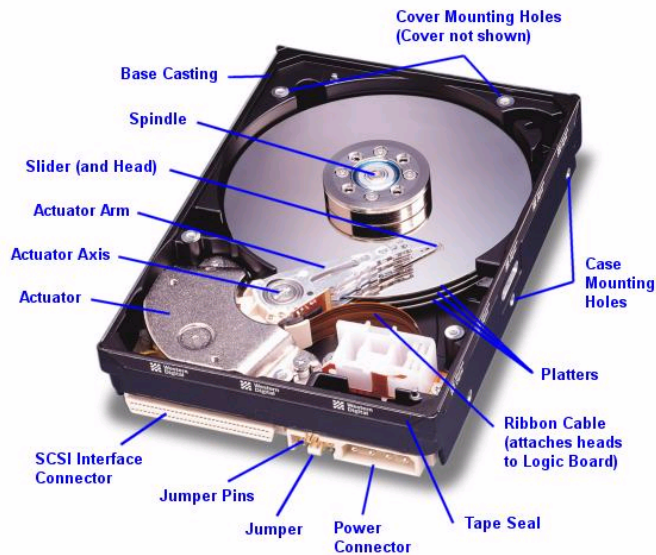

## INTERNAL DISK DRIVE COMPONENTS AND HANDLING TRAYS FOR DISK DRIVES

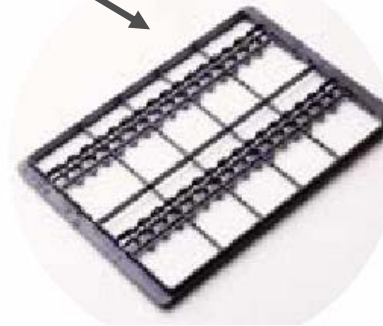

15

In electronics, polycarbonate and polyetherimide (GE's Ultem) components of computer hard drives have been reinforced with nanotubes to render them conductive and very smooth

<http://www.plasticstechnology.com/articles/200411fa2.html>

# CARBON NANOFIBER APPLICATIONS

## FUEL CELLS

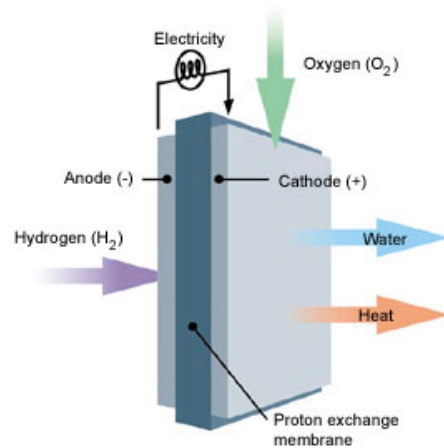

## BIPOLAR PLATES



## ELECTRODE CATALYST SUPPORT IN PEM FUEL CELL (PROTON EXCHANGE MEMBRANE)

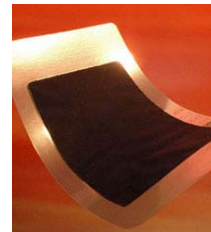

16

It has been a long-standing wish to cut the use of Pt so that fuel cells can be made cheaper," says Yushan Yan of the University of California, Riverside. He and coworkers have found that replacing carbon powder with multiwalled carbon nanotubes (MWNTs) as the catalyst support can cut the amount of Pt required by proton exchange membrane (PEM) fuel cells.

[http://www.materialstoday.com/pdfs\\_7\\_3/resnews.pdf](http://www.materialstoday.com/pdfs_7_3/resnews.pdf)

Since the early 1990s, vapor-grown carbon fibers produced by Showa Denko have increased the useful life of lithium batteries. Drawing on this experience and its expertise in nanotechnology, Showa Denko has developed carbon nanofibers and nanotubes for emerging applications in electronics and biotechnology.

Showa Denko has extensive experience in the design and production of critical components for fuel cell stacks. These products include porous carbon bipolar plates and impervious carbon composite separator plates for phosphoric acid fuel cells as well as graphite composite bipolar plates and gas diffusion layers for proton exchange membrane fuel cells.

[http://www.sdmc.com/fine\\_carbon.asp](http://www.sdmc.com/fine_carbon.asp)

# CARBON NANOFIBER APPLICATIONS

17

## AERONAUTIC COMPONENTS



Use Nanoreinforcements to Improve the Matrix Dependent Properties of Carbon/Epoxy Parts



Nanocompoiste Rocket Ablative Materials (NRAMs)

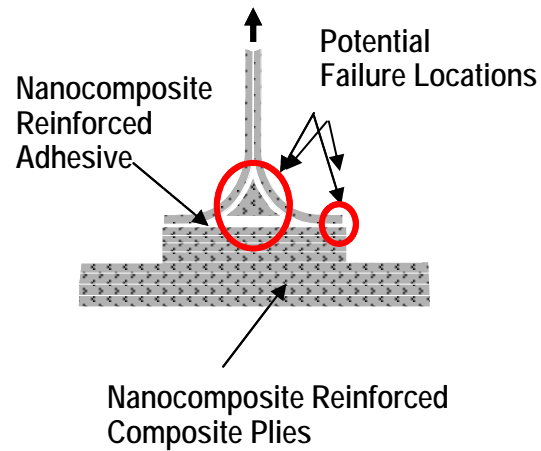

# CARBON NANOFIBER APPLICATIONS

## IMPROVED ELECTRICAL CONDUCTIVE ADHESIVE

- Applications
  - ESD Control of Isolated Metallic Standoffs
  - Electrically Bonded Structural Joints for InterPanel Power/Signal Return Currents
- Electrically Conductive NanoAdhesive Advantages
  - Improved ESD of metallic components w/o added adhesive bead
  - Elimination of interpanel jumper cabling

*Electrically Conductive*

*Bonded Structures*

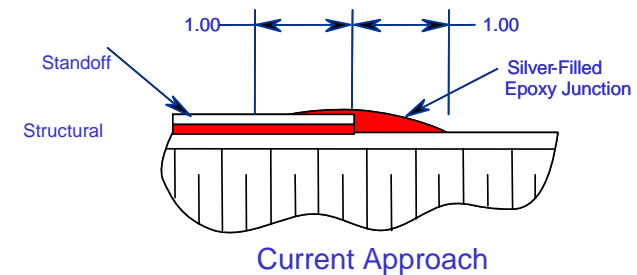

**Conductive Adhesive for ESD Control of Metallic Standoff**



**Inter-Panel Structural Joint with Paste Adhesive**

# CARBON NANOFIBER APPLICATIONS

19

